

Seri Print[®]
THE FUTURE OF DIGITAL DUPLICATING

SP25

Installation Manual

(Version 2.03)

EU

This documentation or any part of it may not be reproduced, stored or transmitted in any form, including, but not limited to electronic, photocopying, mechanical copying, electrostatic copying, recording or other means without express written permission of SeriPrint SA (Pty.) Ltd.

SeriPrint, SeriPrinter, SP100II, SP25, SeriInk, SeriLink and all other related brand names are registered trademarks of SeriPrint South Africa (Pty) Ltd.

Table of Contents

Introduction	4
Specifications	5
Safety Information	6
Unpackaging the SeriPrinter Model 25	8
Installing the SeriPrinter	9
1. Installing the Digital Duplicator paper tray onto the SeriPrinter	10
2. Installing the SeriPrinter Lamps	11
3. Adjusting the height of the SeriPrinter for docking	14
4. Docking of the SeriPrinter and the Duplicator	16
5. Lowering of the Digital Duplicator exit wings	18
6. De-activate the job separator of the Digital Duplicator	18
7. Connecting the SeriPrinter	18

Introduction

The SeriPrinter System produces dry printed output, similar to a copier. This is as a result of it's unique and patented fixing system. This enables the user to print on a wide variety of paper, card, and certain coated stock including vinyl.

The SeriPrinter is a freestanding unit which, operates in conjunction with the Ricoh family of duplicators. No connections to the duplicator are required. The Model 25 is positioned at the paper exit side of the duplicator, after removing the paper delivery tray and repositioning it on the delivery side of the Model 25.

Once the SeriPrinter is set-up, an extended range of paper and card stocks can be printed on. This includes certain vinyl and coated stock which the traditional duplicator ink can not dry on.

A wide range of ink colours are available with the Model 25. Including white, varnish, and a comprehensive range of mixed colours.

Specifications

Machines supported	Digital Duplicator Models C229, C233, C232, C239, C235 and C244 Ricoh , Gestetner, Nashuatec, Rex Rotary, Standard, Savin and Lanier.
Print Speed	60 to 120 Sheets per Minute. (Max 11x17, A3)
Timers	Copies, Lamp Hours
Paper Handling	Automatic speed adjusting vacuum belts.
Paper Collection	As per digital duplicator specification
Paper Size	As per digital duplicator specification
Paper Weight	As per digital duplicator specification
Drying Mechanism	Ink Polymerization
Drying	3 x 400 Watt Lamps
Power	220v
Power Save	Inactivity Automatic Shutdown.
Ink	13 Base Colours plus 10 Standard Colours.
Dimensions Boxed	800mm H, 900mm L, 700mm W
Dimensions Stored	658mm H, 874mm L, 600mm W
Dimensions Set up	658mm H, 1234mm L, 600mm W
Weight	80 kg.
Certification	CE, FCC Class A. 

This devise complies with Part 15 of the FCC Rules.

Federal Communications Commission (FCC) Statement.

This equipment has been tested and found to comply with the limits for a Class A digital device, pursuant to part 15 of the FCC Rules. These limits are designed to provide reasonable protection against harmful interference in a commercial installation. This equipment generates, uses, and can radiate radio frequency energy and, if not installed and used in accordance with the instructions, may cause harmful interference to radio communications. Operation of this equipment in a residential area is likely to cause harmful interference in which case the user will be required to correct the interference at his own risk.

Scientific Management Associates UK Ltd is not responsible for any radio or television interference caused by using other than recommended cables and connectors or by unauthorized changes or modifications to this equipment. Unauthorized changes or modifications could void the user's authority to operate the equipment.

This devise complies with part 15 of the FCC Rules. Operation is subject to the following two conditions (1) this device may not cause harmful interference, and (2) this device must accept any interference received, including interference that may cause undesired operation.

SAFETY INFORMATION

When using your equipment, the following safety precautions should always be followed.

Safety During Operation

WARNING: Indicates a potentially hazardous situation which, if instructions are not followed, could result in a serious injury or death.

CAUTION: Indicates a potentially hazardous situation which, if instructions are not followed, may result in minor or moderate injury or damage to property.

WARNING:

- Connect the power cord directly into a wall outlet and never use an extension cord.
- Only connect the machine to the power source described in the Specifications on page 5 of this manual.
- Do not damage, break or make any modifications to the power cord. Do not place heavy objects on it. Do not pull hard or bend the power cord. These actions could cause an electric shock or fire.
- Do not modify or replace any parts other than the ones specified in this manual
- Since some parts of the machine are supplied with high voltage, touch only the parts specified in this manual.
- To avoid hazardous electric shock, do not remove any covers or screws.
- Do not operate the machine with any cover removed.
- Turn off the power and disconnect the power plug (by pulling the plug, not the cable) if any of the following conditions exists:
 - Liquid is spilled into or on the equipment
 - The equipment needs service or repair.
 - The equipment's cover has been damaged.
- Do not leave the machine unattended while printing is in progress.
- Do not operate the machine when it is not connected to a Digital Duplicator.
- Only attach to the specified Digital Duplicators listed on page 5.
- UV light is hazardous. Use equipment in accordance with the operation manual.
- Do not remove any covers. There are no USER servicable parts inside the machine.

CAUTION:

- Protect the equipment from direct sunlight, dampness or wet weather.
- While printing, do not turn off any portion of the system. This can cause damage to integral components and the belts.
- While printing, do not open the cover.
- While printing, do not unplug the power cord.
- While printing, do not move the machine.
- Keep all liquids off the machine.
- Do not allow paper clips, staples, or other small objects to fall inside the machine
- Be careful of sharp edges when reaching inside the machine to remove mis-fed sheets of paper.
- Do not spill liquid on the machine.
- Do not sit on the machine.
- Do not place the machine against a wall. Ensure that there is a minimum of 50 cm between the machine and the wall.
- Unplug the power cord from the wall outlet before moving the equipment. While moving the equipment, take care that the power cord is not be damaged under the equipment.
- Rubber parts are cleaned with benzine, or other volatile solvent, wipe with a dry cloth.
- Always print with the UV filter cover in place.
- Do not open any panels marked - HIGH VOLTAGE
- Always turn the machine off when finished printing for the day.
- When the machine is not used for long periods, disconnect the power plug from the wall outlet, always pull the plug (not the cable).
- If the machine must be transported by vehicle, please contact your service representative.
- For environmental reasons, do not dispose of all the componets of the equipment or expended supply waste at household waste collection points. Disposal can take place at an authorized dealer or at appropriate collection sites.
- After the adjustable legs have been lowered into position, do not attempt to move the SeriPrinter.
- Raise the adjustable legs before moving the SeriPrinter.

Unpacking the SeriPrinter Model 25

The SeriPrinter Model 25 is wrapped in plastic and packed onto a base carton. Each top corner of the machine has a cardboard corner piece and one piece of cardboard to protect it from damage. The outer box is slotted into a base carton and there are four (4) plastic securing clips that fix the outer box to the bottom base carton.

Follow this procedure when unpacking the machine.

1. Remove the plastic securing clips by pulling on the tab.
2. Pull the outer box off from the top.
3. Remove all the cardboard pieces.
4. Remove the plastic covering the machine.
5. Lift the machine off the base carton.

Note:

There are four handles located on the bottom of each corner of the SeriPrinter. These must be used when lift the machine.

Installing the SeriPrinter.

The following components are packed with the Seriprinter. Ensure all the items have been located before disposing of the packaging.

1. (3) SeriLamps - packed in boxes on the inside of the exit panel of the SeriPrinter.
2. (1) Docking Bracket - wrapped in a tube and placed diagonally on the inside of the exit panel of the SeriPrinter.
3. (4) M4 Screws for mounting the docking bracket - packed into a plastic bag on the inside of the exit panel of the SeriPrinter.

The following procedures are required to be completed prior to switching the SeriPrinter ON.

1. Installing the Digital Duplicator paper delivery tray onto the SeriPrinter.
2. Installing the SeriLamps
3. Adjusting the height of the SeriPrinter for docking.
4. Docking the SeriPrinter and the Digital Duplicator.
5. De-activating the job separator of the Digital Duplicator
6. Lowering of the Digital Duplicator exit wings.
7. Connecting the SeriPrinter.

1. Installing the Digital Duplicator paper delivery tray onto the SeriPrinter.

- 1.1. Remove the Paper Delivery Tray and its mounting brackets from the Digital Duplicator. Refer to the Digital Duplicator service manual.
- 1.2. The SeriPrinter paper exit side has two fixed mounting points that are used to secure the paper delivery tray brackets and the paper delivery tray, removed from the Digital Duplicator. Secure the Digital Duplicator brackets. See Figure 1. Mount the Paper Delivery Tray and secure onto their brackets now on the SeriPrinter Exit Panel.

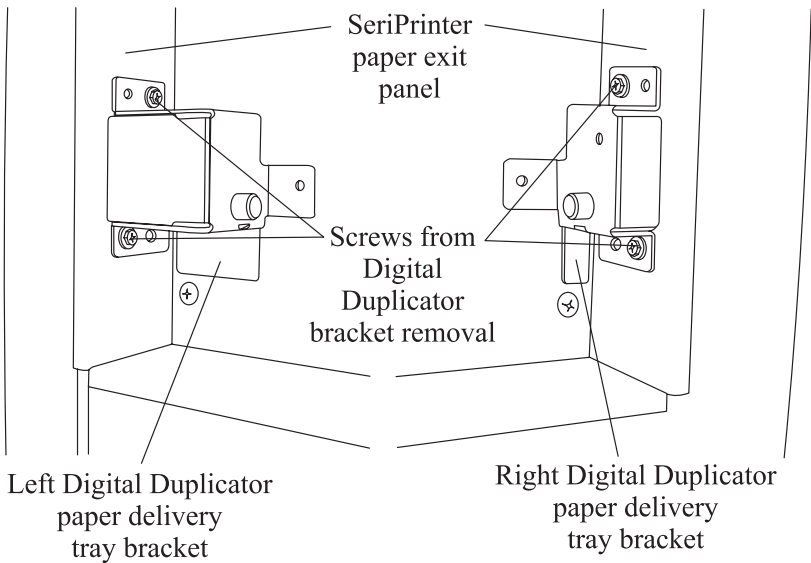

Figure 1

2. Installing the SeriPrinter Lamps.

- 2.1. Open the top cover of the SeriPrinter.
- 2.2. Place a piece of paper (A3 / 11x17) onto the vacuum bed belts to prevent screws from falling into the vacuum bed.
- 2.3. Remove the (4) screws located beneath the top cover hinge. See Figure 2.

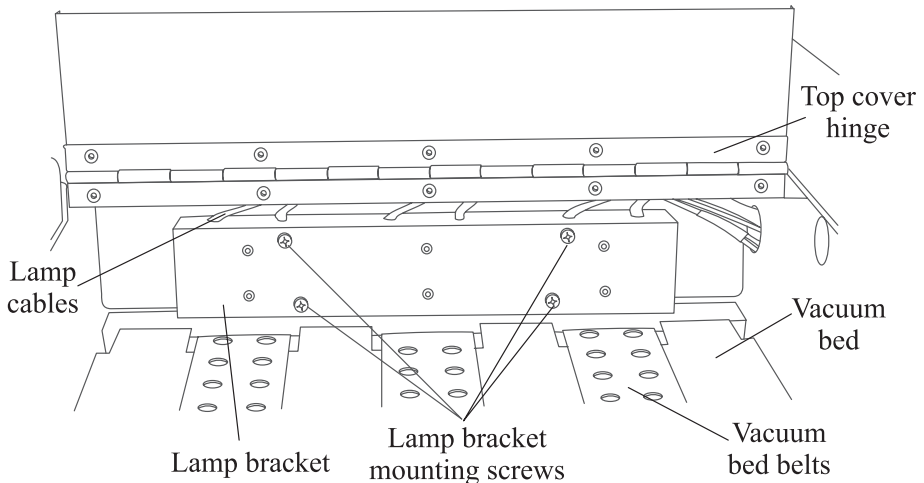

Figure 2

- 2.4. Carefully remove the bracket. Place it onto the vacuum bed with the connectors facing up. See Figure 3.

Note:

When removing the lamp bracket, take care not to damage the lamp cables secured to the lamp connector blocks on the bracket.

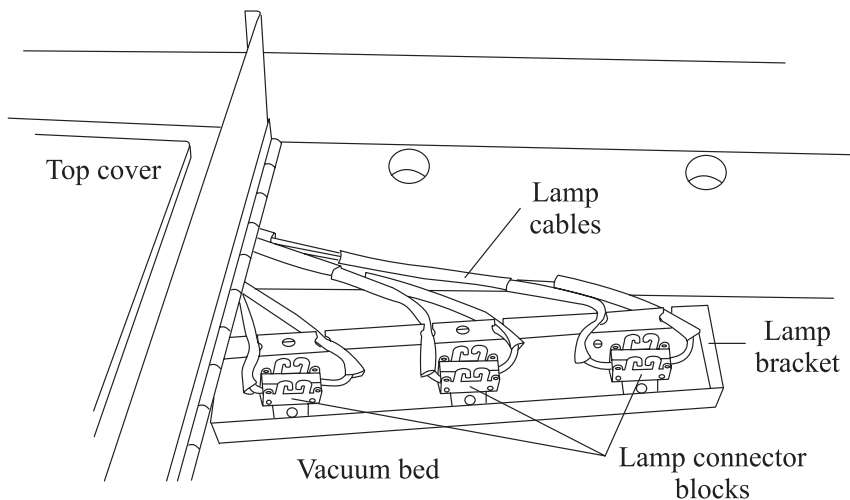

Figure 3

- 2.5. Locate the three (3) lamps.
- 2.6. Remove the lamps from their packaging.

Warning:

DO NOT touch the glass bulb of the lamp. Handle the lamp at the ceramic connector end. In the event the bulb is touched, clean with the cloth provided in the lamp packaging.

- 2.7. Plug all three (3) lamps into the available connector blocks.

Note:

Each lamp has two (2) connector pins. One pin is larger than the other. This prevents the lamps being installed incorrectly.

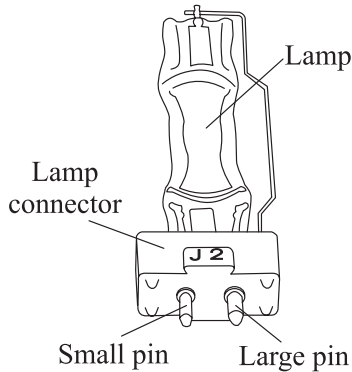

Figure 4

2.8. Replace the lamp bracket.

Note: When replacing the bracket, take care not to damage the lamps when they pass through the holes of the lamp housing.

2.9. Mount the bracket and secure with the four (4) screws removed in 2.3.

Note: Ensure that the lamp cables are not pinched between the bracket and the lamp housing.

2.10. Ensure that the lamp connectors have not disconnected during the installation procedure.

Important Note: When transporting the SeriPtiner ensure the lamps are removed. The lamps will be damaged if left in the machine when transported.

3. Adjusting the height of the SeriPrinter.

Once the paper delivery tray has been fitted onto the SeriPrinter, the machine can be prepared for docking to the Digital Duplicator. The SeriPrinter needs to be aligned so that the vacuum bed belts (green belts) are horizontal to the Digital Duplicators exit bed. Refer to Figures 5 and 6.

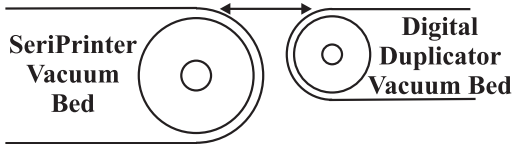

Figure 5

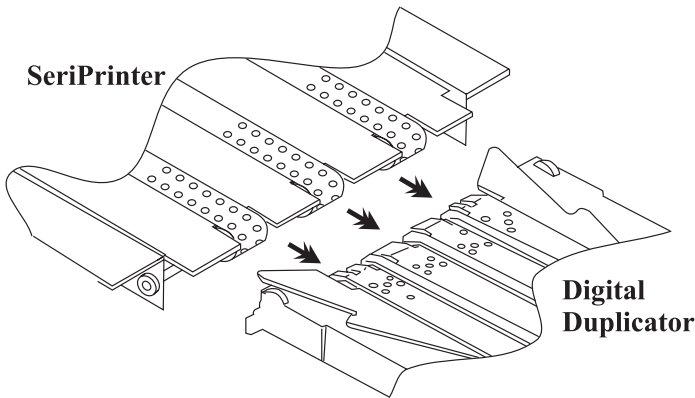

Figure 6

Note: When positioning the machines note that the **SeriPrinter must not be placed closer than 50cm from a wall.**

3.1 Before proceeding, move the SeriPrinter to its final position.

Caution: After the adjusting legs are lowered into position, do not attempt to move the **SeriPrinter**

3.2. Lowering the 4 adjustable legs and feet.

The SeriPrinters legs are located in front of each wheel.

Using a 15mm wrench, turn the fixed nut of the adjustable leg. Continue to raise the machine until the vacuum beds of each machine are evenly aligned. Refer to Figure 7.

Note: **Ensure the height is adjusted correctly. If the SeriPrinters is higher than the Digital Duplicators, the paper will collide when exiting the Digital Duplicator. If lower, the paper will collide on the SeriPrinter top bracket or lamp box.**

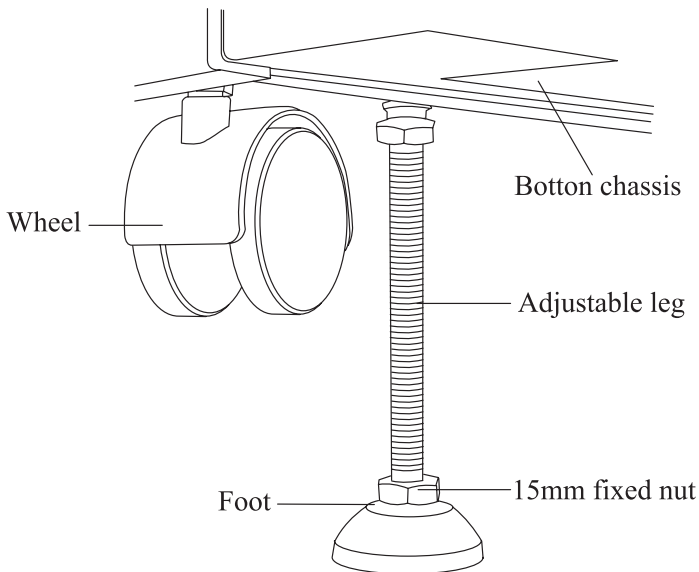

Figure 7

4. Docking the SeriPrinter and the Digital Duplicator.

Before beginning this procedure please ensure that the Digital Duplicator paper delivery tray brackets have been removed. Procedure 1.1.

- 4.1. Attach the Docking bracket to the Digital Duplicator where the paper delivery tray brackets attached, using the four (4) supplied screws. Refer to Figure 8.

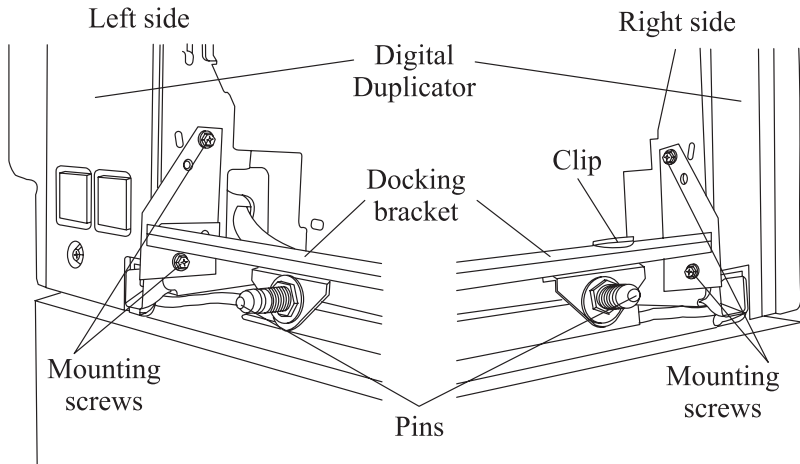

Figure 8

- 4.2. Slide the Digital Duplicator to the SeriPrinter. Do not move the SeriPrinter. The pins and clip of the Docking bracket must align with the holes on the SeriPrinter. When the two machines are docked correctly they will “CLICK” into each other. Refer to Figure 9.

Note:

When the two machines are latched they must “click” together.

- 4.3. To disconnect the two machines, press the release button on the rear panel of the SeriPrinter. This will release the pins and the Digital Duplicator can be moved. See Figure 9.

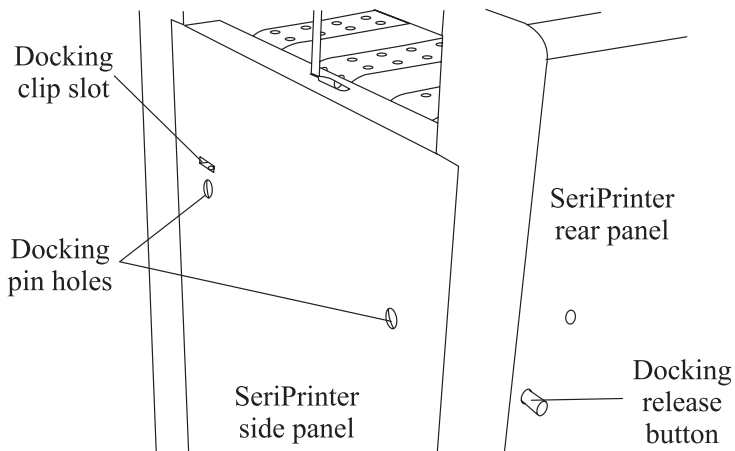

Figure 9

If the machines do not dock together then check that the height of the SeriPrinter is correct.

The pins on the Docking bracket may require fine adjusting. Loosen the securing nuts on each side of the bracket. Reposition the pin within the positioning hole of the bracket and tighten the nuts. See Figure 10.

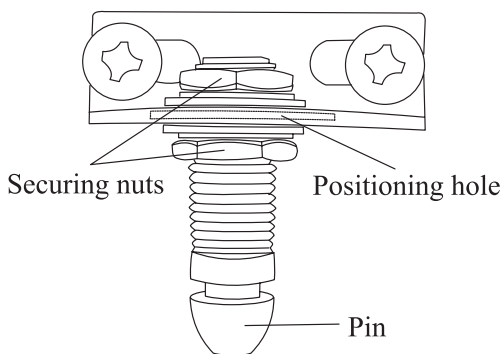

Figure 10

5. Lowering the paper wing guides of the Digital Duplicator

The Digital Duplicator's exit wing guides must be put in the lower position. This will ensure a smooth delivery of paper through the SeriPrinter. Failure to lower the wings will cause the paper to collide with the SeriPrinter entrance bar or the lamp housing box causing a paper jam.

Refer to the Digital Duplicator's operators manual for the procedure to lower the wings.

6. De-activate the Job separator of the Digital Duplicator.

The job separation function on the Digital Duplicator must be de-activated in the service mode. Failure to de-activate the job separator may cause damage to the mechanism.

Refer to the Digital Duplicator's operators manual for the procedure to de-activate the job separator.

7. Connecting the SeriPrinter.

Connect the power cord directly into a main socket. Do not use an extension cord. The SeriPrinter is now ready to be used. Please refer to the Operators manual on how to use the machine.

Note:

Wait for the SeriPrinter to be in the READY state before operating the Digital Duplicator. Failure to do so will cause the paper to jam on the SeriPrinter's jam pin and causing a paper exit jam in the Digital Duplicator.
